



IDEC's SE2L Safety Laser Scanner and Fanuc's CRX Robot controller connection

Version 1.0

15- Jan - 2024



Table of Contents

1. Introduction	3
1.1 About a SE2L Safety Laser Scanner	3
1.1.1 Precautions	3
1.1.2 Power supply	3
1.1.3 Wire color and function	4
1.2 About Fanuc CRX Robot Controller	5
1.2.1 Pin Configuration	5
2. Connection Specifications	7
2.1 Connection for Basic function: Single SE2L	7
2.1.1 Connection Diagram Single SE2L	8
2.2 Connection Diagram: Single SE2L with optional Area switching	9
2.3 Connection Diagram: Connection system of 2 x SE2L	10
2.4 Connection Diagram: Switching scanning areas and Auxiliary Terminals	13



1. Introduction

This manual outlines the wiring specification and connection guidelines for IDEC's SE2L Safety Laser Scanner and Fanuc's CRX Robot controller. This manual also covers connections with SE2L's accessories such as the SE9Z-RT2SV and SE9Z-T connection boxes.

1.1 About a SE2L Safety Laser Scanner

SE2L emits pulsed laser beam which is reflected on a rotating mirror within the configured protection zone. When the emitted laser beams are reflected back from an object its distance is measured. This chapter describes safety precaution when wiring the SE2L.

1.1.1 Precautions

During electric wiring make sure that all devices are disconnected from power supply. Switch off all the power supply during wiring. Confirm that power supply is OFF.

1.1.2 Power supply

Make sure that power supply is within the range of 24V DC 10%. For battery operation, power supply should be within the range of 24V DC -30% / +20%. SE2L could be damaged if rated output voltage exceeds this range.



Danger • For safety, switch OFF the power supply during electrical wiring.



1.1.3 Wire color and function

Table 1 shows the color of each lead wire, signal name, function, and description of SE2L-H05LP. It is recommended to use the shielded cable for wiring.

Table 1: Wire color and function

Color	Signal	Function	Description
Brown	+ 24 DC	Power	Power Supply: 24V DC
Blue	0V DC	Power	Power Supply: 0V DC
Red	OSSD1	Output	Protection zone output 1
Yellow	OSSD2	Output	Protection zone output 2
Red/Black	OSSD3 / WARNING 1	Output	Protection zone output 3 / Warning zone output 1
Yellow/Black	OSSD4 / WARNING 2	Output	Protection zone output 4 / Warning zone output 2
Purple	IN_A	Input	Area switching Input A
Gray	IN_B / MUTING 3	Input	Area switching Input B / Muting input 3
White	IN_C / OVERRIDE1 / ENC1_A	Input	Area switching Input C / Override input 1 / Encoder input 1_A
Pink	IN_D / MUTING 1 / ENC1_B	Input	Area switching Input D / Muting input 1 / Encoder input 1_B
Green	IN_E / EDM1	Input	Area switching Input E / External device monitoring 1
Purple/Black	IN_Ā	Input	Area switching Input A invert
Gray/Black	IN_Ḃ / MUTING4	Input	Area switching Input B invert / Muting input 4
White/Black	IN_Ĉ / OVERRIDE2/ ENC2_A	Input	Area switching Input C invert / Override input 2 / Encoder input 2_A
Pink/Black	IN_Ḍ / MUTING2 / ENC2_B	Input	Area switching Input D invert / Muting input 2 / Encoder input 2_B
Green/Black	IN_Ē / EDM2	Input	Area switching Input E invert / External device monitoring 2
Yellow/Green	RESET 1	Input	Reset input 1
Yellow/Blue	RESET 2	Input	Reset input 2
Orange	RES_REQ1 / MUT_OUT1 / AUX_OUT1	Output	RES_REQ1 : ON when resuming the OSSD1/2 signal from interlock state using external inputs. MUT_OUT1 : ON when OSSD1/2 signals are performing muting operation. AUX_OUT1 : Synchronous signal / Error / Window contamination error / Window contamination warning. (see section 3.21 for details)
Orange/Black	RES_REQ2 / MUT_OUT2 / AUX_OUT2	Output	RES_REQ2 : ON when resuming the OSSD3/4 signal from interlock state using external inputs. MUT_OUT2 : ON when OSSD3/4 signals are performing muting operation. AUX_OUT2 : Synchronous signal / Error / Window contamination error / Window contamination warning. (see section 3.21 for details)
White/Blue (TP)	RS-485+	Communication	Communication protocol RS-485
White/Red (TP)	RS-485-	Communication	Communication protocol RS-485
Shield wire	FG	—	Frame ground

1.2 About Fanuc CRX Robot Controller

1.2.1 Pin Configuration

The manual specifies the pin configuration of Fanuc CRX Robot controllers to which the SE2L can connect to.

Note: An I/O-terminal block conversion module is required to connect to the SE9Z terminal box. In this case the internal terminal block A05B-2695-J160.

The internal terminal block conversion module is located as shown below.

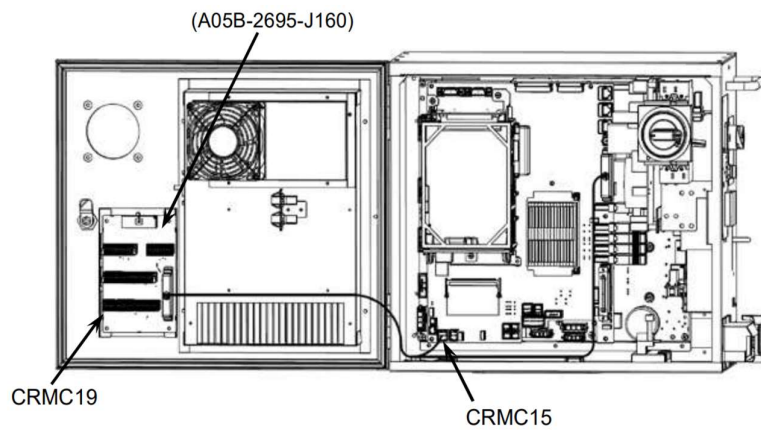

Figure 1: Fanuc CRX controller layout

The specific terminals where the SE2L connections are to be made are CMRC19 for safety connections and JRM18 for power.

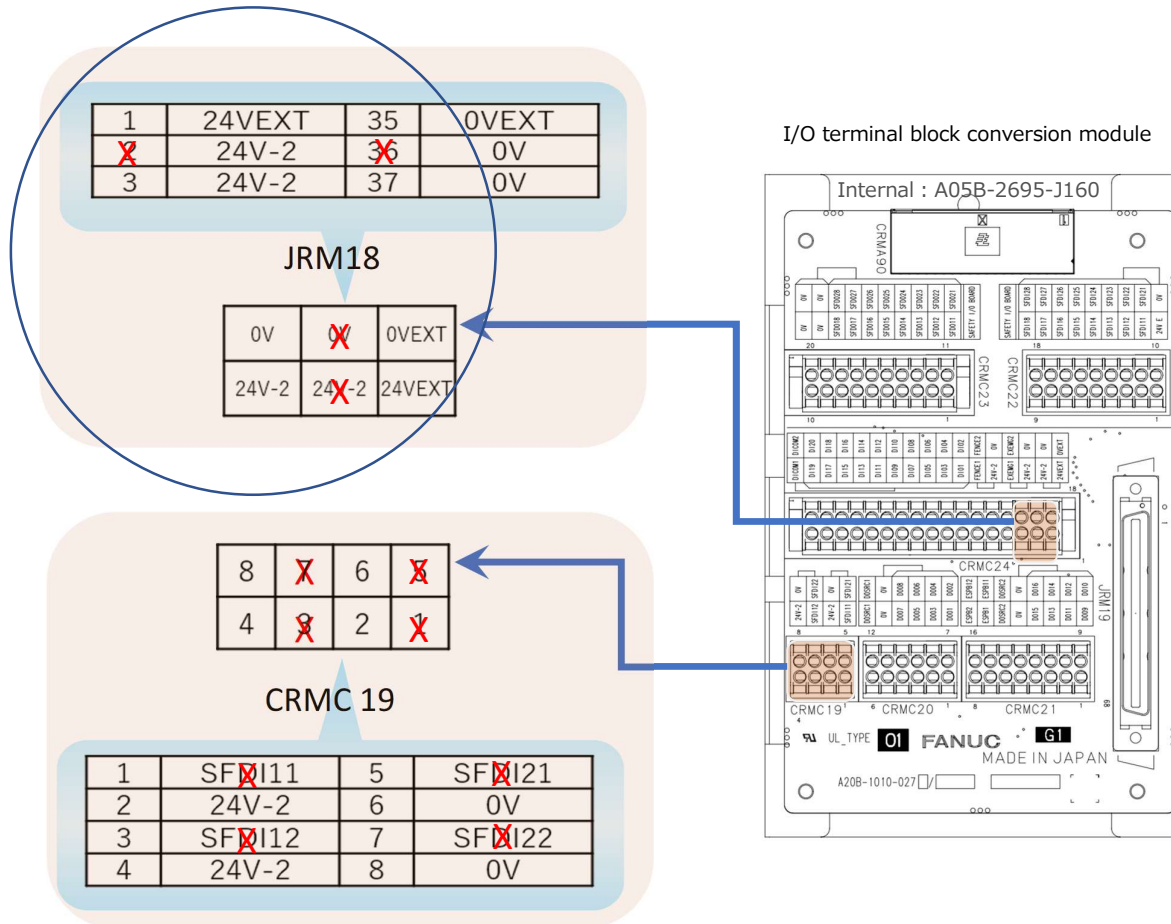

Figure 2: CMRC19 and JRM18 blocks on the internal terminal conversion module.

Note: The terminals for power on the CMRC19 even though present **should not** be connected for power. Instead, the SE2L is to be powered by the terminals of JRM18.

The terminals 1,3,5 and 7 on the CMRC19 are to be considered for safety functionality and the terminals 2 and 36 on the JRM18 are to be considered for power connections to the SE2L laser scanner.





2. Connection Specifications

This section enumerates the connection specifications for various configurations in which the SE2L can be connected in conjunction with the Fanuc CRX robot controller.

2.1 Connection for Basic function: Single SE2L

The connection of SE2L with the CRX controller should employ the cable SE2L-H05LP.

The three major connections to be considered when connecting an SE2L laser scanner to the Fanuc CRX robot controller are as such.

1. Safety Output 
2. Power 
3. Reset 

The wires for the safety output on the SE2L are represented by the colors Red, Yellow, Red/Black and Yellow/Black, the wires for power are represented by Brown and Blue as shown in the table below:

Table 2: Wire configuration of SE2L-H05LP cable

SE2L-H05LP cable			
Color	Name	Function	
RED	safety out1	OSSD1	
YELLOW	safety out2	OSSD2	
RED/BLACK	safety out3	OSSD3	
YELLOW/BLACK	safety out4	OSSD4	
YELLOW/GREEN	RESET1	Reset Request 1	
YELLOW/BLUE	RESET2	Reset Request 2	
BROWN	24V	24V	
BLUE	0V	0V	
shield	FG	Frame ground	

2.1.1 Connection Diagram Single SE2L

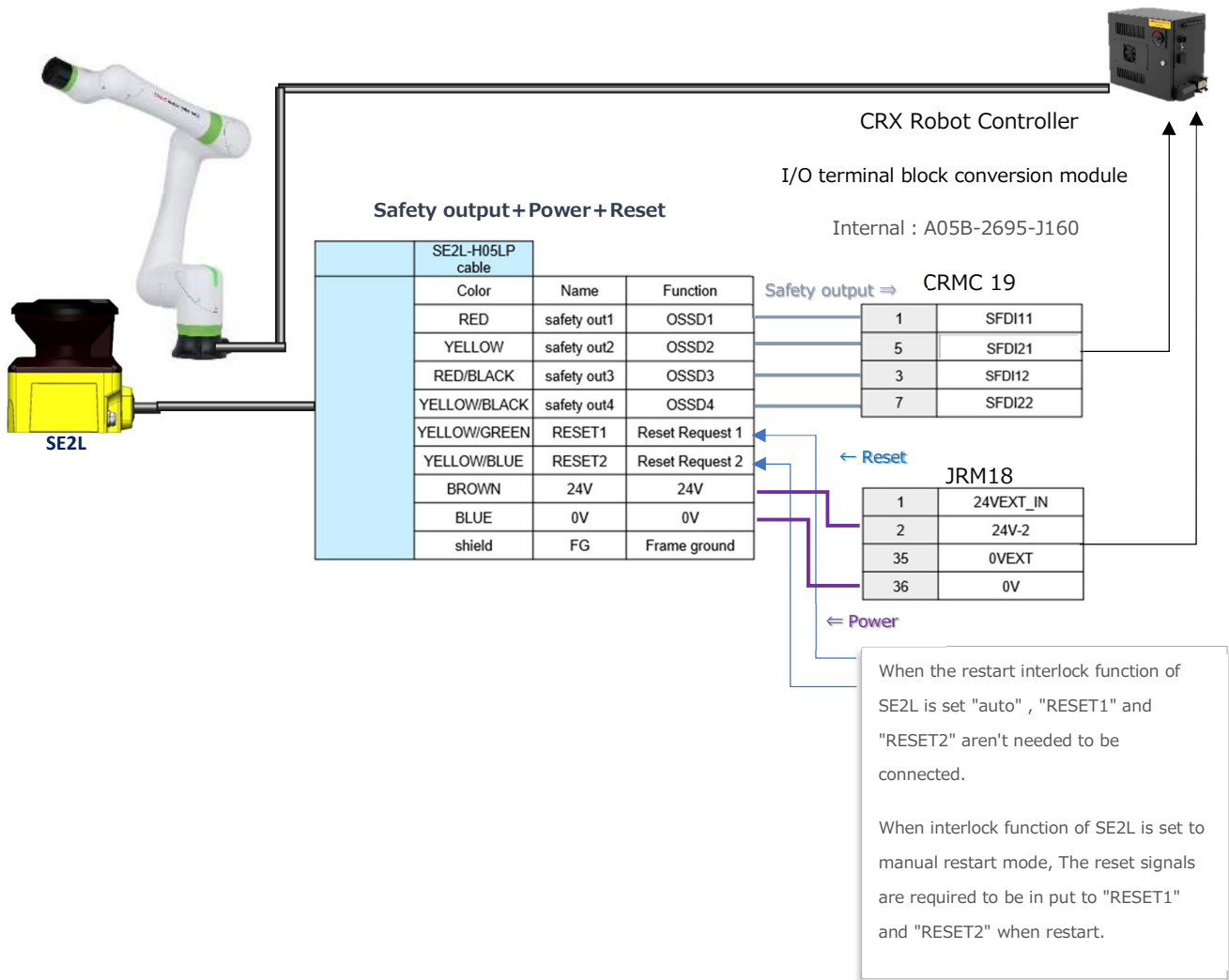

Figure 3: Connection diagram: Single SE2L to CRX controller

The connection specification for a single SE2L is as shown above. The safety outputs OSSD1 through OSSD 4 are to be connected to terminals 1,3,5 and 7 of the CRMC19 respectively and the 24V and 0V connections are to be made to terminals 2 and 36 of JRM18 for power to the SE2L.

The SE2L has connections for 'Reset' functionality represented by Green and Blue wires. When the restart interlock function is set to 'AUTO' these connections need not be made but when the restart interlock function is set to manual the Yellow/Green and Yellow/Blue wires can be used to manually reset the system using an auxiliary device like a push button, for example, when the system shuts down due to presence detection.

2.2 Connection Diagram: Single SE2L with optional Area switching

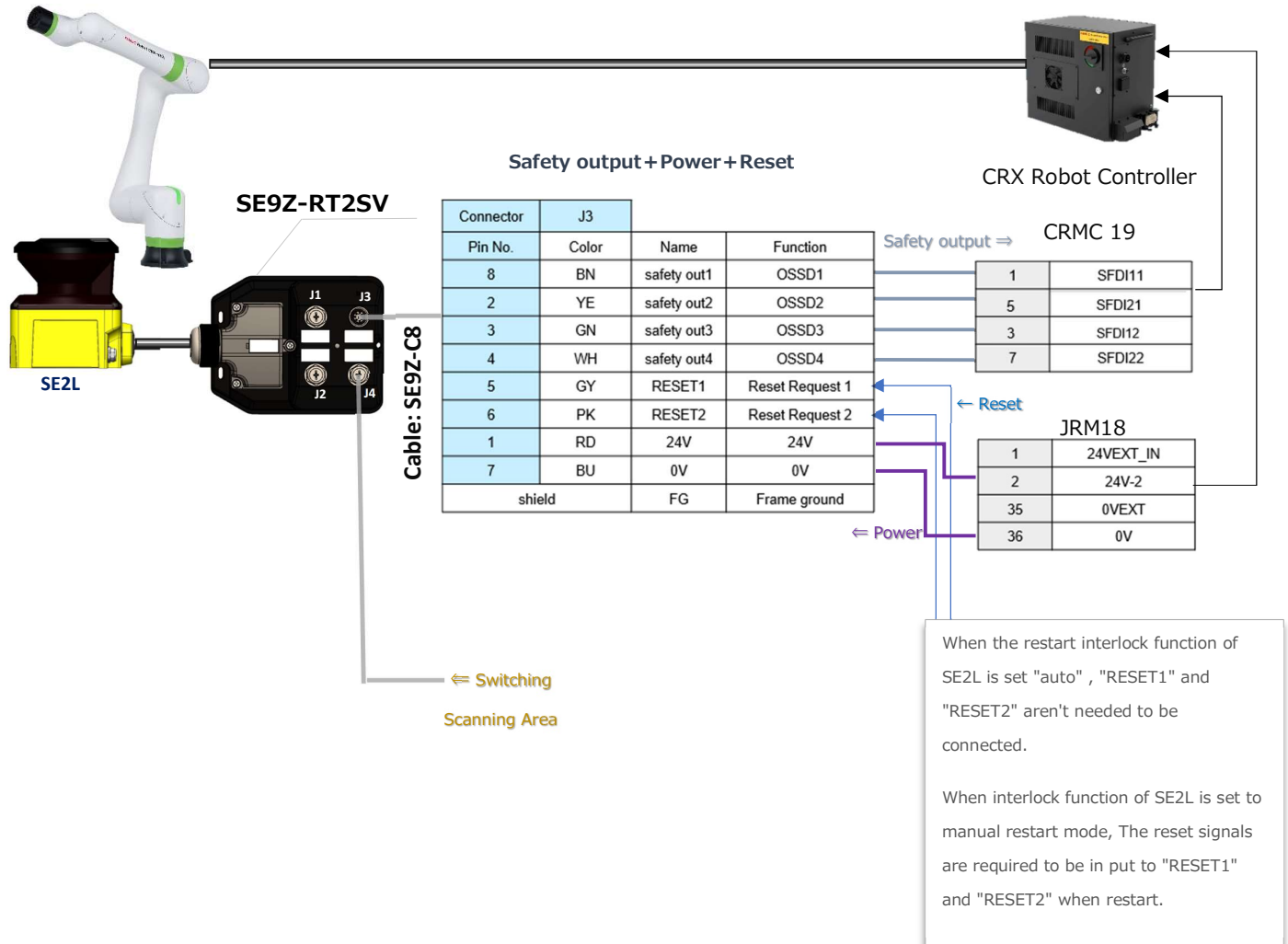

Figure 4: Connection Diagram: Single SE2L with optional Area switching.

The connection specification for a single SE2L with optional Area switching is as shown above. This connection specification employs the use of an SE9Z-RT2SV. The use of this connection terminal box enables additional contact wires to be connected for optional area switching.

Connections to the CRX controller are the same as those for just a single SE2L laser scanner with one exception of employing a SE9Z-C8 cable being connected to the J3 terminal of the SE9Z-RT2SV. Additionally, extra contacts are connected to terminal J4 to enable for area switching.



Area Switching:

Area Switching is a feature of the SE2L where a maximum of 32 sets of area can be configured and set to operation as and when required. However, the maximum configurable area number differs depending on the selected function such as, muting and dual protection.

External input signals are provided to the SE2L for switching the area. Each signal has a pair of normal and inverted signal. For example, it is necessary to provide both input signal IN A and inverse IN A signal to switch the area. An error will occur if IN_A and inverse IN_A signals do not complement each other. Area in use will be displayed in the 7 segment LED of SE2L.

There are maximum 5 input pairs (a pair is combination of normal and inverted signal) to the SE2L. therefore, it can operate with maximum 32 sets of area.

2.3 Connection Diagram: Connection system of 2 x SE2L.

This connection diagram specifies the connections to be made to use two SE2L Safety Laser scanners in a Master-Slave configuration as a part of a single system. This employs the use of SE9Z-C5 cable for Master-Slave connections and SE9Z-C8 cable for Safety output, Power and Reset connections.

The color coding of the SE9Z-C8 cable is as shown below:

Table 3: SE9Z-C8 cable color coding

Connector	J3		
Pin No.	Color	Name	Function
8	BN	safety out1	OSSD1
2	YE	safety out2	OSSD2
3	GN	safety out3	OSSD3
4	WH	safety out4	OSSD4
5	GY	RESET1	Reset Request 1
6	PK	RESET2	Reset Request 2
1	RD	24V	24V
7	BU	0V	0V
shield		FG	Frame ground

- The colors Brown, Yellow Green and White are to be connected for **Safety output function**,
- The colors Red and Blue are to be connected for **Power** to the SE2L
- The colors Grey and Pink can be used for optional **Reset** functionality.

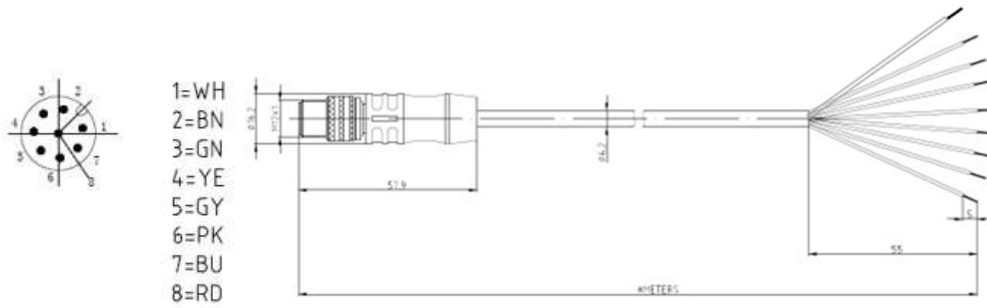

SE9Z-C8□F
□=2 : 2m
5 : 5m
10 : 10m
20 : 20m

Figure 5: SE9ZC8xF cable

The color coding of the SE9Z-C5 cable is as shown:

Table 4: SE9Z-C5 cable color coding

Connector	J1	
Pin No.	Color	Name
1	YE	RS485-
5	WH/YE	RS485+
3	BU	0V
4	WH/BU	24V
2	shield	FG

- The colors Yellow and White/**Yellow** are to be connected for RS485 connections.
- The colors Blue and White/**Blue** are to be connected for Power to the slave connection.

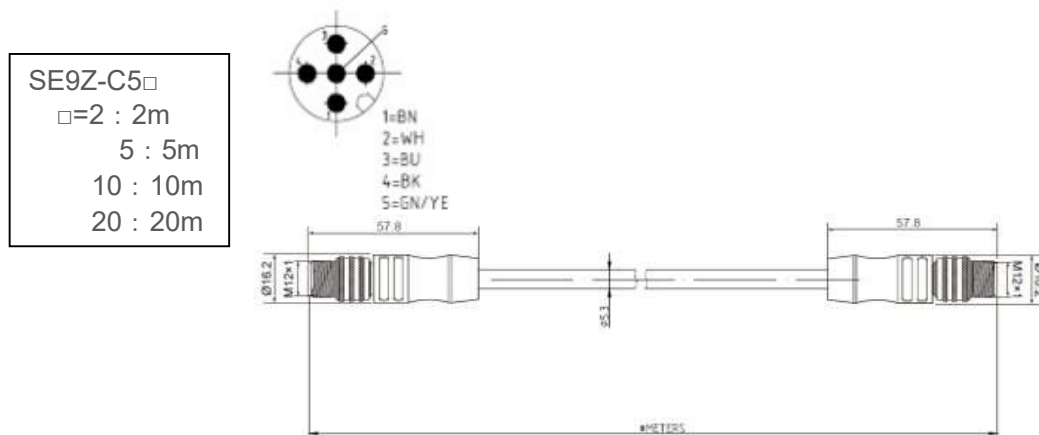

SE9Z-C5□
□=2 : 2m
5 : 5m
10 : 10m
20 : 20m

Figure 6: SE9Z-C5x cable

The connection diagram employing two SE2L Laser scanners is as shown:

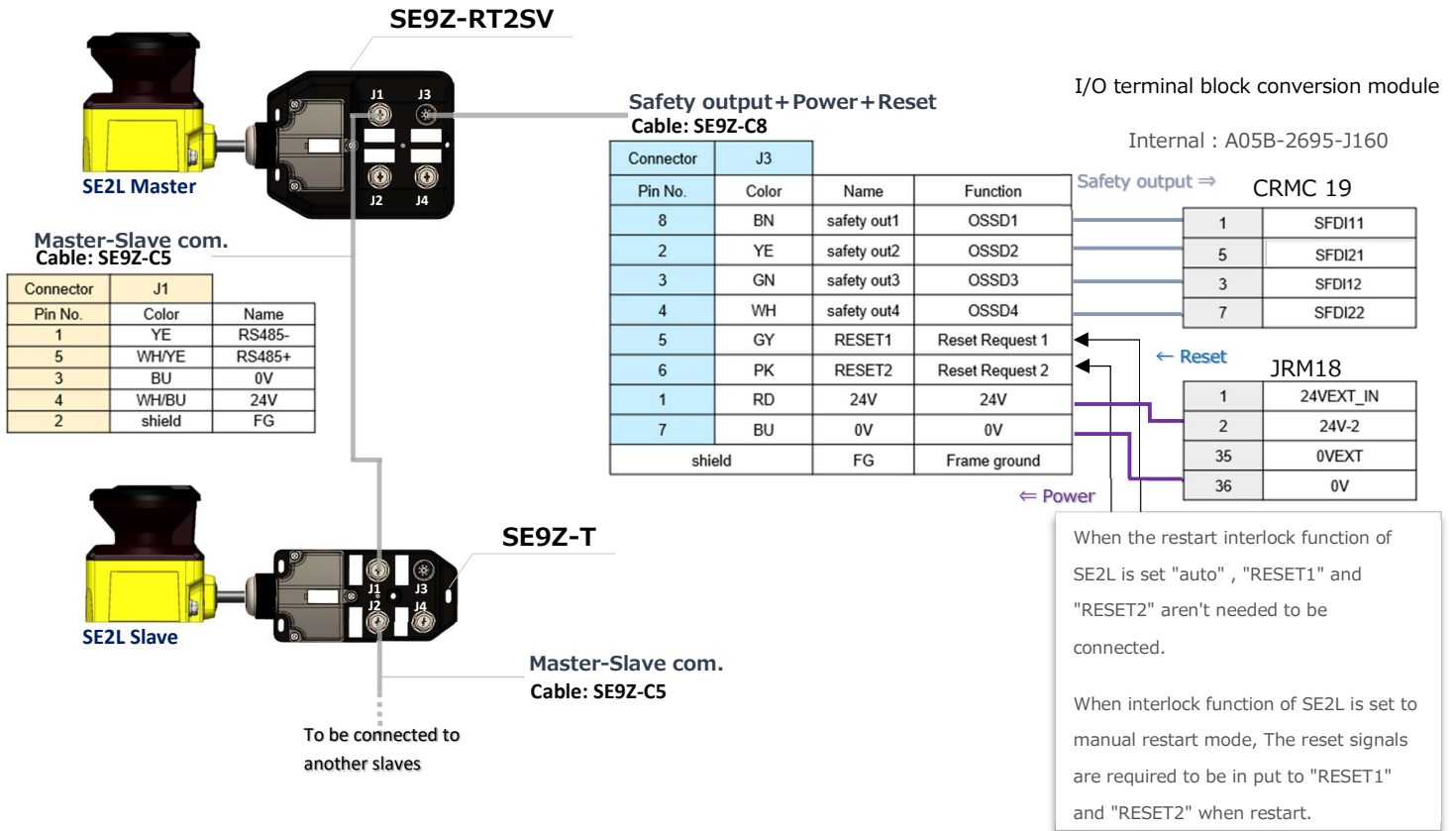

Figure 7: Connection Diagram - Two SE2L Master Slave Configuration

Above is the connection diagram employing two SE2L Laser scanners in a Master-Slave configuration. The terminals J1 and J1 of the connection boxes SE9Z-RT2SV and SE9Z-T are used to connect two SE2L Safety laser scanners to each other in Master-Slave configuration. Connections for Power and RS485 communications using the SE9Z-C5 cable are to be made for this.

The terminal J3 of the SE9Z-RT2SV connection box is connected to the CRX Robot controller with the SE9Z-C8 cable. The cables Brown, Yellow, Green and White are to be connected to the CRMC19 terminal pins 1,3,5, and 7 of the CRX controller for Safety output functionality. The cables Red and Blue are to be connected to the JRM18 terminal pins 2 and 36 for power to the SE2L. The cables Grey and Pink can be connected optionally for RESET functionality.

Note: In a Master-Slave configuration, only connections **up to two** SE2L Laser scanners are permitted by the design with respect to the power availability of the CRX Robot controller. Additional SE2L Safety laser scanners can be connected by employing an external 24V DC Power Supply if need be.

2.4 Connection Diagram: Switching scanning areas and Auxiliary Terminals

In addition to the Master-Slave configuration shown above, more functionalities can be connected such as Switching scanning areas and other auxiliary terminals for example. This can be achieved by employing the SE9Z-C8 cable connecting between the connection boxes and the CRX controller.

The connection table for Switching Scanning Areas is as shown:

Table 5: SE9Z-C8 cable color coding

Connector	J4		
Pin No.	Color	Name	Description
1	RD	IN_A	Area switching input A
2	YE	IN_B	Area switching input B
3	GN	IN_C	Area switching input C
4	WH	IN_D	Area switching input D
5	GY	IN_A-	Area switching input A invert
6	PK	IN_B-	Area switching input B invert
7	BU	IN_C-	Area switching input C invert
8	BN	IN_D-	Area switching input D invert
shield		FG	Frame ground

Shown below is the color coding of the SE9Z-C8xxF cable for switching the scanning areas configuration with 4 inputs and 4 inverted inputs allowing for a switching range up to 16 different areas, the terminal J4 of the SE9Z-RT2SV connection box serves as the point of connection for this configuration.

The terminals J2 on the SE9Z-RT2SV (Master) connection box and terminals J3 and J4 on the SE9Z-T (Slave) can be used as connection points for auxiliary terminals.

Connection diagram for Switching scanning areas and auxiliary terminals is as shown.

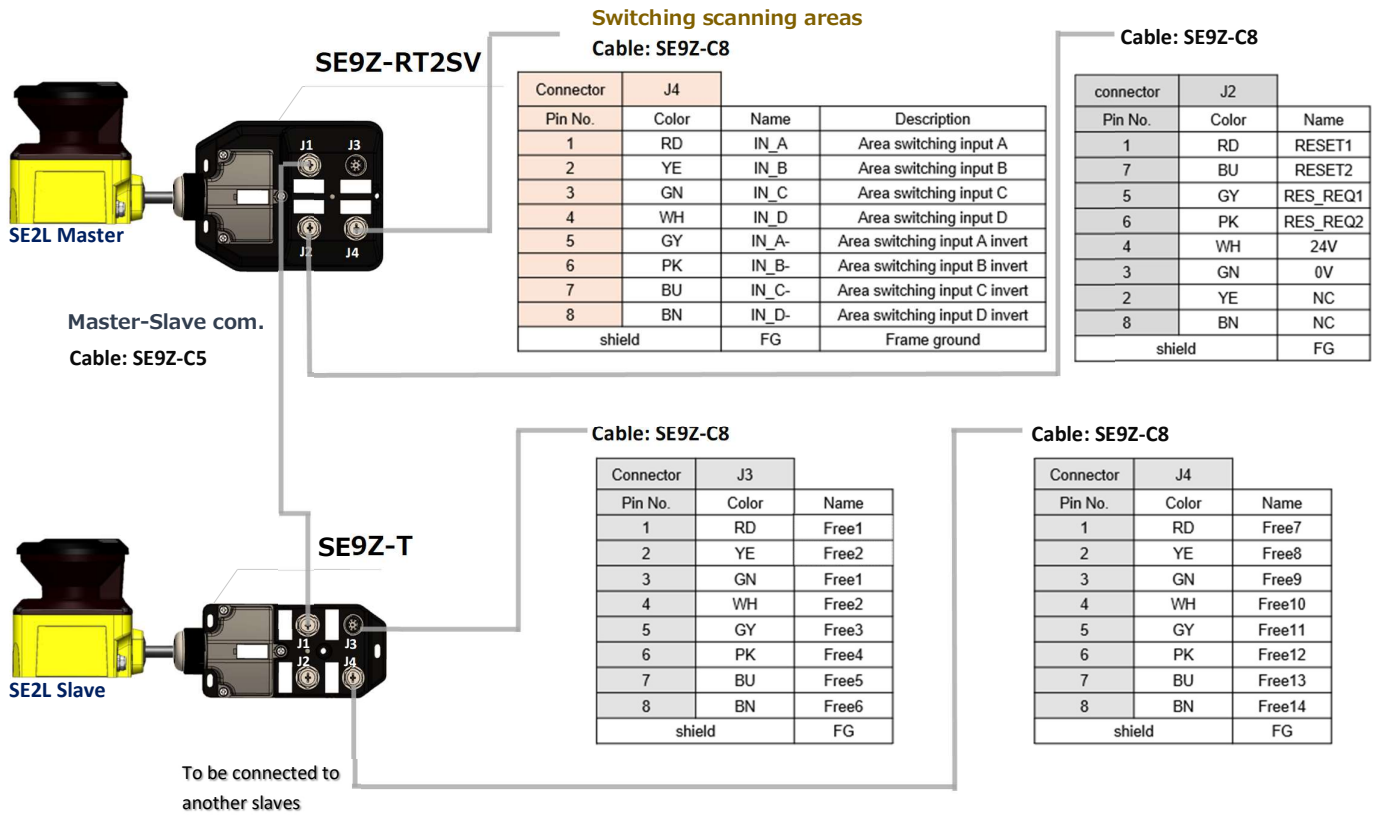

Figure 8: Connection diagram for Switching scanning areas and auxiliary terminals

Shown above is the connection diagram specifying the connections for switching the scanning area and auxiliary terminal functionalities.

For auxiliary terminals, as mentioned before, terminals J2 of SE9Z-RT2SV (Master) and J3 and J4 terminals of SE9Z-T (Slave) connection boxes can be used. Power connections and Reset connections are to be made according to the tables in the circuit diagram shown above.